

## JA-120PW Bus combined PIR and MW motion detector

The JA-120PW is a bus component of the JABLOTRON 100+ system. It is used for the detection of human movement in building interiors. The combination of PIR and microwave (MW) detection provides great immunity against false alarms. The detector works like a classic PIR detector, however when PIR detects movement in a guarded place, the MW part is activated and confirms the previous PIR activation. Only then an alarm is triggered and is sent to the control panel. The detector takes one position in the system and should be installed by a trained technician with a valid certificate issued by an authorised distributor.

### Installation

Given the principle and detection characteristics of the MW detector, the best results can be achieved when the detector is installed in a corner of a room. No moving objects (e.g. waving curtains above a radiator) or animals should be in the detector's field of vision. There should be no obstacles in front of the detector which could obstruct its view and it should not be installed near metal objects (they could affect the MW field). It is also not possible to install two and more detectors in an area where MW transmitters could affect each other.

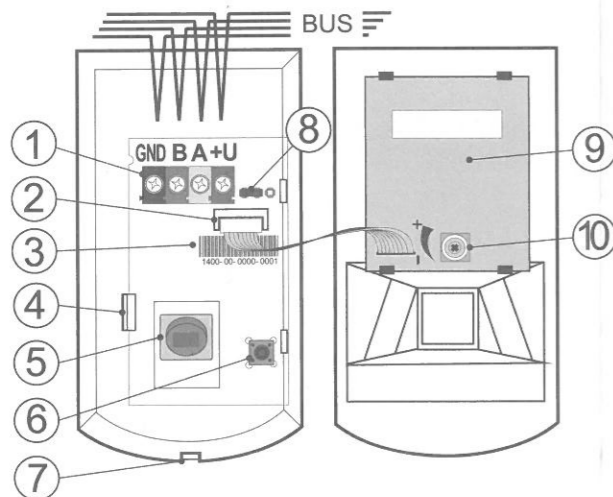

Figure: 1 – digital bus terminals; 2 – MW part connector; 3 – production code; 4 – PCB tab; 5 – PIR sensor; 6 – tamper contact; 7 – cover tab; 8 – test jumper; 9 – MW sensor; 10 – MW sensitivity settings;

- Open the detector cover by pushing the tab (7). Avoid touching the PIR sensor inside (5) – you could damage it.
- Take out the PCB – it is held by tabs (4). It is not necessary to unplug the connector (2) of the MW part.
- Punch through the holes for the screws and the cable in the plastic base. The recommended detector installation height is 2.5 m above the floor.
- Insert the bus cable and attach the plastic base to the wall using screws (vertically, with the cover tab (7) facing downwards).

**Always switch the power off before connecting the detector to the system bus.**

- Put the PCB back and connect the bus cable to the terminals (1).
- Proceed according to the control panel installation manual. Basic procedure:
  - When the device is powered, the yellow LED starts flashing repeatedly to indicate that the module has not been enrolled into the system.
  - Go to the **F-Link** software, select the required position in the **Devices** tab and launch enrollment mode by clicking on the **Enroll** button.
  - In the next window, click on **"Scan/add new BUS devices"**, select the detector from the list and double-click on it to confirm your selection. You can also enrol the device by pressing the tamper contact in the detector (6). The yellow LED light will shut down after successful enrollment.
- Close the detector cover.

#### Note:

The detector can also be enrolled into the system by entering its serial number (5) in the F-Link program. The serial number is on a label with a bar code which is placed inside the detector (3). All numbers shall be entered (example: 1400-00-0000-0001).

If you want to remove the detector from the system, delete it from its position in the control panel.

### Detector internal settings

The detector properties can be set in the **Devices** tab of the F-Link software. Use the **Internal settings** button, on the same position as the detector, to open a dialog window where you can set following (factory settings are marked with \*):

**Activation indicated by LED:** disable\* / enable movement indication by a red LED. Indication always works in Service mode

**PIR immunity level:** determines a level of immunity to false alarms. *Standard\** combines basic immunity with a fast sensor reaction. *Increased* has stronger immunity with a slower reaction time.

**MW immunity level:** determines the level of analysis performed by the MW motion detector. *Standard\** combines basic immunity with a fast sensor reaction. *Increased* has stronger immunity and provides a slower reaction time.

### Detector Testing

Check the functioning of both sensors using a jumper (8) when the control panel is in **Service mode**. **Warning:** Confirmation of activation by the MW detector can't be carried out when the control panel is unset therefore it's not possible to fully test its function and configuration.

The PIR detector is equipped with a 110°/12m lens. Coverage – see Fig 2. Check the coverage with the jumper (8) in the **"PIR"** position. Movement is indicated by a red LED.

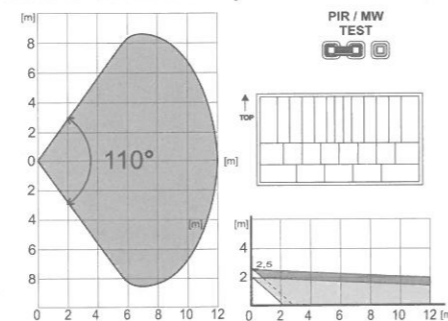

Fig 2: Coverage characteristics can be changed by using an alternative lens:

JS-7904	Designed for long corridors - with a working range of up to 20 m <b>Increased immunity cannot be used with this lens!</b>
JS-7910	Equipped only with the upper beam covering 120 degrees/12 m and doesn't cover the floor (can ignore the movement of small pets on the floor)
JS-7902	Vertical curtain – it does not cover an area but creates a detection wall (can be used to create a barrier and report its breach)

**After changing a lens, it's necessary to test whether the detector sufficiently covers the area.**

The MW detector reacts to movement from in a 1 m to 15 m range. The detection range is set by a trimmer (10). In some cases, the detector can detect movement of non-metal materials behind fixed obstacles (behind a thin wall, a door, glass, flowing water in plastic pipes etc.).

It is recommended to set the MW detection range the way it won't exceed the field of view of PIR. Testing is carried out by placing the jumper (8) in the MW position. MW activation is indicated by a red LED. Given the principle of MW, its coverage characteristics may significantly differ depending on a size, shape and facilities of the room in which the detector has been installed. Especially regarding metal surfaces which cause reflection or shielding of the signal generated by MW.

**During installation, it's always necessary to test whether the detector sufficiently covers the area.**

## JA-120PW Bus combined PIR and MW motion detector

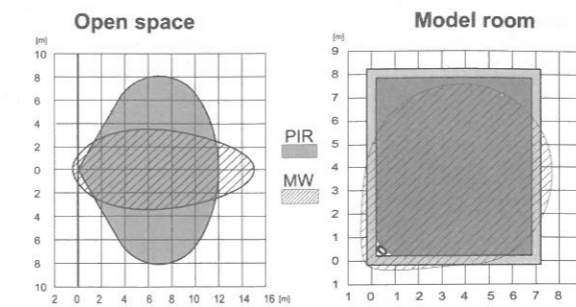

Fig 3: Detection coverage characteristics in open space and in a model room – installation in a corner.

Disconnect the jumper completely after testing the coverage of the PIR/MW parts of the detector.



### Technical specifications

Power from the control panel bus 12 V (9 ... 15 V)  
 Current consumption in standby mode 5 mA  
 Current consumption for cable choice 25 mA  
 Recommended installation height 2.5 m above the floor  
 Detection angle / PIR coverage 110 degrees/12 m (standard lens)  
 Detection angle / MW coverage 24 degrees/15 m (in open space)  
 Detection angle / MW coverage 90 degrees/15 m (see the model room)

MW Frequency 9.35 GHz  
 Dimensions 60 x 110 x 55 mm  
 Weight 110 g

Classification Security grade 2 / Environmental class II  
 - according to EN 50131-1, EN 50131-2-4

- environment Indoor general  
 - operating temperature range -10 to +40 °C

- average humidity 75 % RH, non-condensing  
 - certification body Trezor Test s.r.o. (no. 3025)

Also complies with ETSI EN 300 440-1, EN 60950-1, EN 50130-4, EN 55022  
 ERC REC 70-03

Can be operated according to

Operation requires notification national telecommunication offices of Finland, France, Italy, Serbia and Montenegro, Spain, Sweden, UK



JABLOTRON ALARMS a.s. hereby declares that the JA-120PW is in a compliance with the relevant Union harmonisation legislation: Directives No: 2014/53/EU, 2014/35/EU, 2014/30/EU, 2011/65/EU. The original of the conformity assessment can be found at [www.jablotron.com](http://www.jablotron.com) - Section Downloads.



**Note:** Although this product does not contain any harmful materials we suggest you return the product to the dealer or directly to the manufacturer after use.